

PIPE RECYCLING LINE
管材撕碎线



2022年3月印刷

Domestic sales
国内销售热线Tel : 86-(0)20-39960299

Oversea sales
海外销售热线Tel : 86-(0)20-84729983

广州市联冠机械有限公司 GUANGZHOU 3E MACHINERY CO.,LTD Webstie: www.3e-machinery.com / www.3e-recycling.com
中国·广州市番禺区大龙街泰安路西六横街4号 No.4 XI LIU HENG STREET,TAIAN ROAD,DALONG,PANYU DISTRICT,GUANGZHOU,CHINA



3E机械官网



公司微信

■ 卧式管材撕碎线 HORIZONTAL PIPE SHREDDER RECYCLING LINE



3E机械卧式管材撕碎线，主要针对PE管材、钢丝骨架塑料复合管材的撕碎、分选以及回收，采用两级撕碎实现塑料与钢丝的有效分离，再配备磁选机将钢丝从塑料中彻底分选出来。

3E mechanical horizontal pipe shredding line mainly aims at the shredding, sorting and recycling of PE pipe- wire frame plastic composite pipes, and adopts two-stage shredding to obtain plastic. Plastic is effectively separated from the steel wire, and then the shredding line is equipped with a magnetic separator to completely separate steel wires from the plastic.

适用范围：

适合钢丝骨架塑料复合管：直径50—800毫米，≤6米
(推料行程可根据物料长短定制，超出规格需进行预切割处理)

产能：800-1500kg/h

物料分选效果：塑料纯度≥99.9%，钢丝纯度≥99.9%

设备特点：

- 结构紧凑、运行稳定，操作方便、维护简便，
- 采用针对性刀具结构，确保撕碎效率，
- 刀具采用优质高强度模具钢，耐磨性好，使用寿命长，
- 主机箱体接触物料位均采用耐磨钢材，增强设备安全性及稳定性，
- 推管机采用变频电机结合变频调速，有效提升运行效率，
- 采用西门子PLC控制系统，自动化程度高，
- 符合欧洲机械生产安全标准（CE认证）。

Application scope:

The equipment is suitable for wire frame plastic composite pipes which are smaller than or equal to 6 meters, with the diameter being 50-800 mm. (The pushing length can be customized according to the length of materials, and pre-cutting is required if the specification is exceeded)

Capacity: 800-1500kg/h

Material sorting effect: plastic purity ≥ 99.9%, steel wire purity ≥ 99.9%.

Features:

- Compact structure, high stability in running, high convenience in operation and high easiness in maintenance.
- A targeted tool structure is adopted to ensure the shredding efficiency.
- The tool is made of high-quality high-strength die steel, and is good in abrasion resistance and long in service life.
- The material contacting position of the mainframe box body is made of abrasion resistant steel to enhance the safety and stability of the equipment.
- The pipe pusher adopts a pole-changing motor combined with frequency conversion speed regulation, to effectively improve the operation efficiency.
- A Siemens PLC control system is adopted, and the degree of automation is high.
- The equipment is in line with European machinery production safety standards (CE certification).

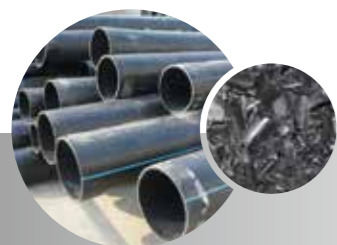

PE管材
PE PIPE



WIRE FRAME PLASTIC
COMPOSITE PIPES
钢丝骨架塑料复合管

■ 管材单轴撕碎机 PIPE SINGLE SHAFT SHREDDER

该系列是根据物料外形来设计的，适用于撕碎长条形管材，对管材的处理效率有显著提高，用户可根据管材直径的大小选择相应的机型。

Our pipe shredder series is specifically designed for processing long and thick walled plastic pipe. The shredder can be adjusted to suit various pipe diameters.

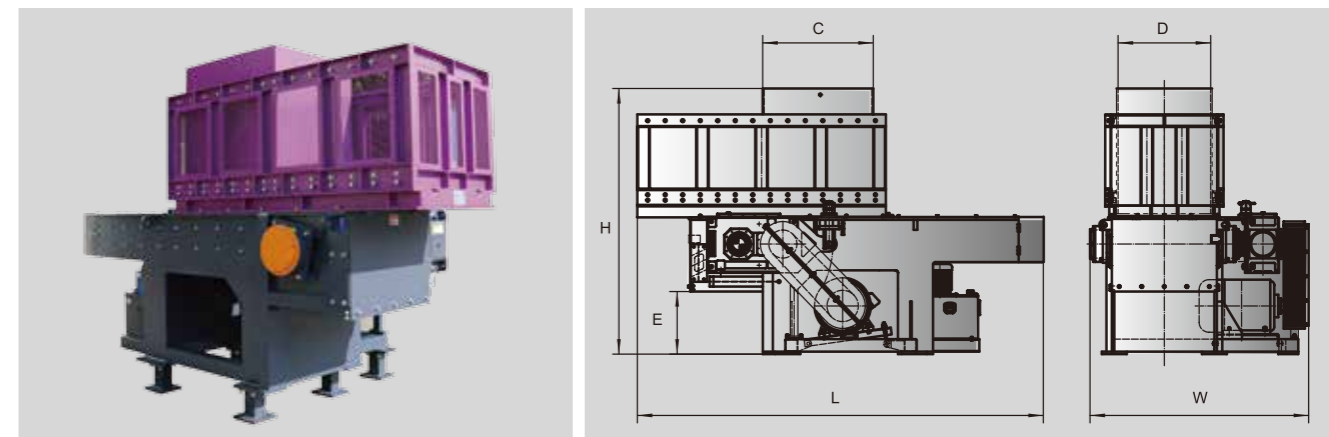

Model Item	WTP2260	WTP3080	WTP4080
外形尺寸Dimension L/W/H(mm)	2148 X 1379 X 1774	2962 X 1713 X 2092	3240 X 1779 X 2116
粉碎室尺寸Cutting Chamber C/D(mm)	452 X 542	860 X 740	860 X 740
出料口高度 Height of discharge port E(mm)	546	500	500
油缸行程Cylinder Stroke(mm)	500	750	900
刀体回转直径Rotor Diameter(mm)	φ224.7	φ300	φ390.3
主轴转速Main Shaft Speed (r/min)	83	83	74
筛网孔径Screen Mesh(mm)	φ25	φ40	φ40
动刀数量Rotor-knives(PCS)	32	46	46
定刀数量Stator-knives(PCS)	2+2	2	2
主机功率Main Motor Power(KW)	18.5	30	37
液压电机功率Hydraulic Motor Power(KW)	2.2	2.2	2.2
设备重量Weight(KG)	Approx 1700	Approx 2700	Approx 4800

Model Item	WTP40100	WTP40120	WTP40150
外形尺寸Dimension L/W/H(mm)	3368 X 1972 X 2116	4100 X 2566 X 2218	4768 X 2886 X 2575
粉碎室尺寸Cutting Chamber C/D(mm)	980 X 940	1140 X 1100	1300 X 1400
出料口高度 Height of discharge port E(mm)	500	600	810
油缸行程Cylinder Stroke(mm)	900	1100	1300
刀体回转直径Rotor Diameter(mm)	φ390.3	φ390.3	φ390.3
主轴转速Main Shaft Speed (r/min)	74	74	74
筛网孔径Screen Mesh(mm)	φ40	φ40	φ40
动刀数量Rotor-knives(PCS)	58	70	94
定刀数量Stator-knives(PCS)	2	2	3
主机功率Main Motor Power(KW)	45	55	75
液压电机功率Hydraulic Motor Power(KW)	2.2	5.5	5.5
设备重量Weight(KG)	Approx 4800	Approx 6000	Approx 7100

说明：
1.筛网指的是默认的规格，可按用户要求在φ40-φ100之间定制；
2.行程S可按客户要求制作；
3.以上规格仅供参考，如有更改恕不另行通知。请在订购前与我司销售代表确认。

NOTICE:
1.The above data of screen mesh is the default specification,. The screen size ranges betweenφ40-φ100 according to user's requirement.
2.Cylinder Stroke "S" can be ordered according to user's requirement
3.The above specifications are only for reference and subject to change without prior notice, please confirm with our sales representative when making order.