

STEP-1.0 单轴开包机-预破碎 SIZE REDUCTION

该设备适用于各种打包或成捆的农膜，吨袋等的预破碎，通常用于打包薄膜类回收解决方案的前端。针对泥沙含量大的物料设计，能一次性将整包物料打散并剪切成均匀的尺寸，便于对泥沙进行预处理掉，减少对后端主机的磨损。

Usually the Pre-shredder is used for crushing agriculture film, woven bag etc. And it can be located at the start of plastic film recycling plant.

Designed for materials with large silts&sands and content, the entire package can be broken up and cut to a smaller size at one time, and the silts & sands can be easy pretreated out to reduce wear on the back-end equipments.

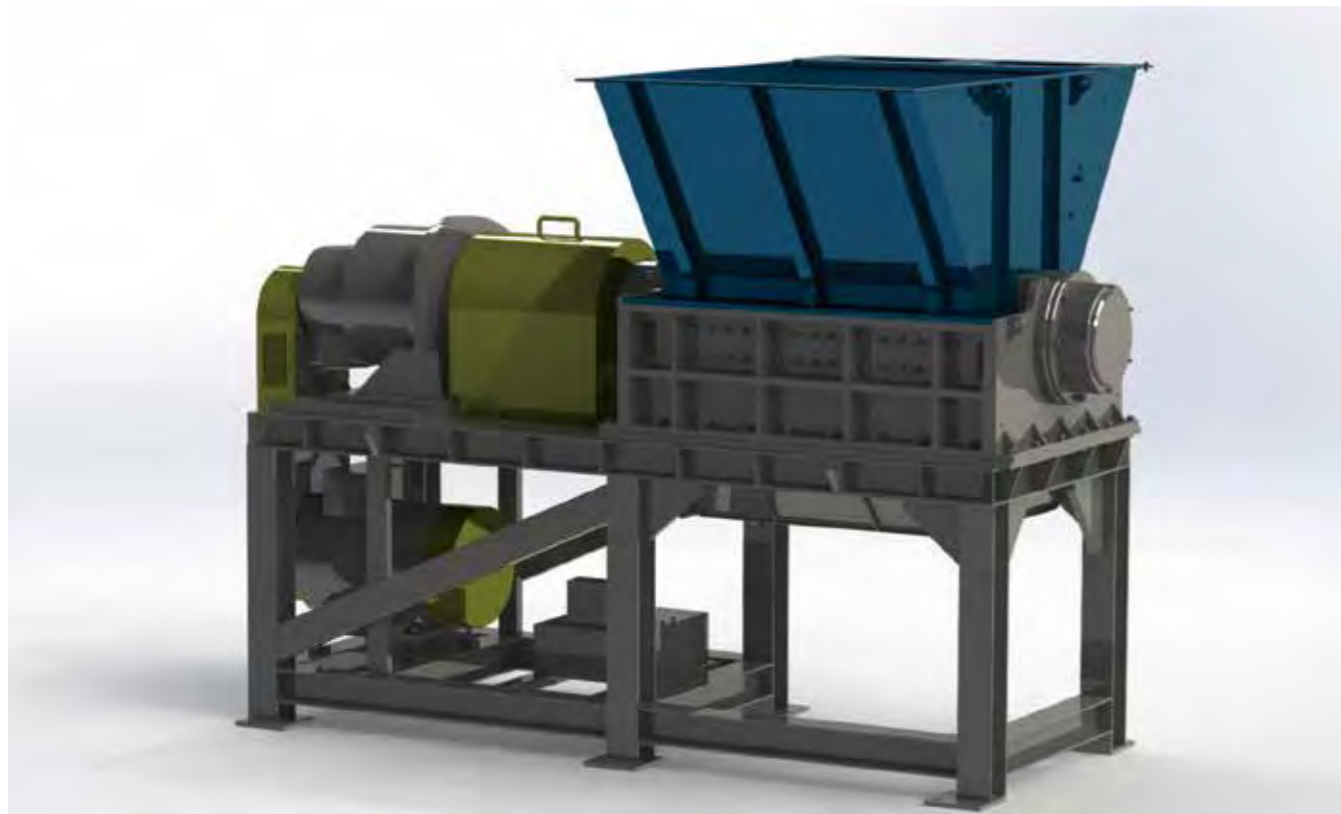

技术特点：

- 低速、大扭矩剪切、低粉尘、低噪音；
- 刀具由耐磨材质制成，磨损后可以重新堆焊使用，维护频率低；
- 箱体模块化设计，配备独立侧板及轴承座，方便维护；
- 独立控制电箱，西门子PLC自动控制。

Technical features:

- Low speed, large torque shear, low dust, low noise;
- The cutter is made of wear-resistant material, which can be used again after wear, with low maintenance frequency;
- Modular design of cutting chamber, equipped with independent side plate and bearing seat, convenient for maintenance;
- Independent electric cabinet, Siemens PLC automatic control.

SPECIFICATION I 规格

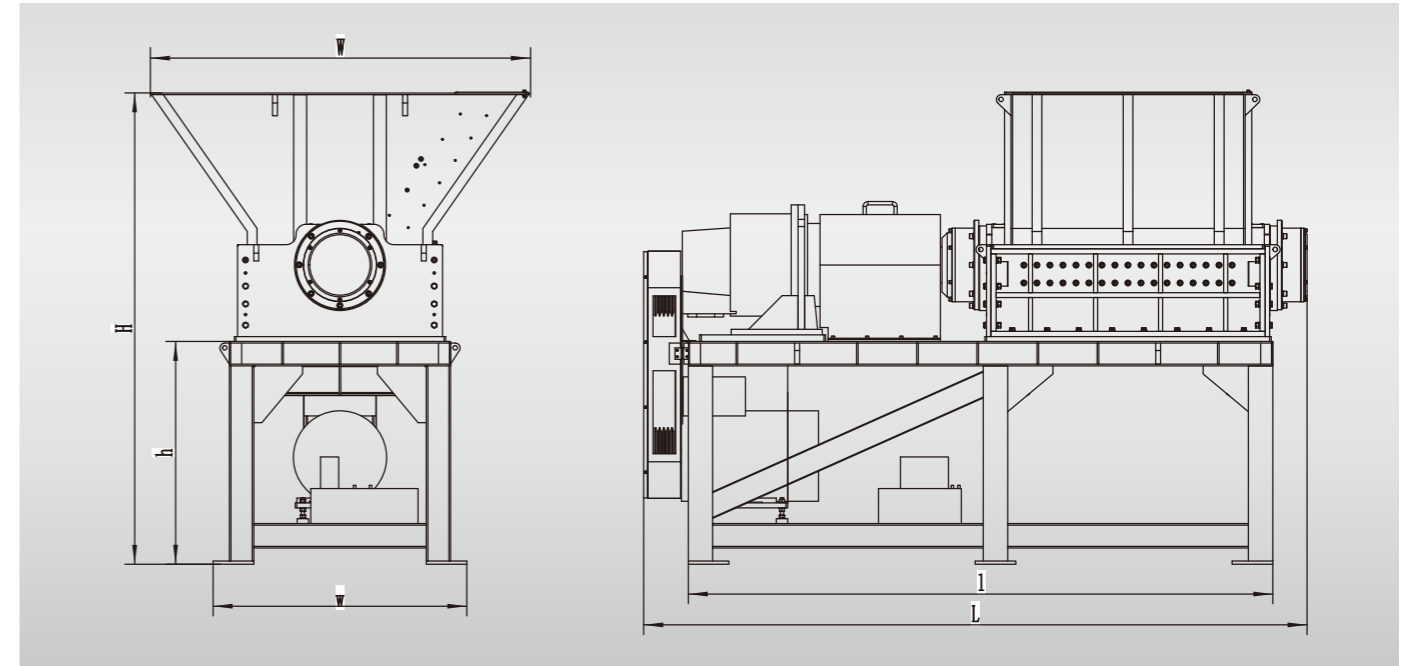

Model Item	WPR65140(I)	WPR65140(II)	WPR80200
功率Power(kw)	75	132	250
转速Main shaft speed (r/min)	15.4	21	21
产量/吨 Output / ton	2.5	5	10
刀辊长度Rotor length (mm)	1390	1390	2030
动刀数量Rotor-knives (PCS)	32	48	96
动刀尺寸 L/W/H (mm)	105X60X35	105X60X35	105X60X35
刀体回转直径Rotor Diameter (mm)	660	660	790
外形尺寸Dimension L/W/H/l/w/h(mm)	4080/2330/2820/3600/1560/1270	4250/2360/3030/3740/1560/1430	5000/2400/3500/4200/1700/1600
进料口尺寸Material inlet (mm)	1420X1780	1420X1780	2060X1910
出料口尺寸discharge port (mm)	1420X1000	1420X1000	2060X1130

说明：

1. WPR80200动力传输结构还未完全确定，现根据主轴减速机花键连接估算得到外形尺寸；
2. WPR65140(I) (II)的箱体，压料斗组件通用。采用联轴器连接减速机主轴估算外形；
3. 三种规格机器，动刀组件，下定刀组件均通用；
4. 以上规格仅供参考，如有更改恕不另行通知。请在订购前与销售代表确定。